

Datasheet

Agnostic Spring Load Force Sensor

PT215 – Strain gauge sensor

V0.9 (draft)

FEATURES

- High sensitivity / high linearity
- Low power consumption
- High durability
- Small footprint
- SMD solderable
- Small size
- Spring load sensor

TYPICAL APPLICATION

- Input systems with clip mounting
- Force sensing in display applications (3D-Touch)
- Force sensing in industrial applications (e.g. end stop)

DESCRIPTION

The PT215 sensor is a piezo-resistive sensor offering low profile, low power consumption, high sensitivity and high durability. The Micro Strain Gauge material is directly printed on a FR4 substrate. The PT215 sensor is produced as a SMD type device with solder pads.

Enabled by its unique properties, the PT215 sensor provides accurate measurements of small forces in a wide range of applications. The cantilever type spring load sensor detects micromovements of any type of material.

The PT215 sensor consists of an array of piezoresistors in a Wheatstone-bridge configuration. When a force is applied, the deformation of the sensor leads to a change in resistance, which is then converted to a voltage output signal.

ORDERING INFORMATION

Order Number	Part	Size	Packaging	MOQ
tbd	PT215	8.4 * 5.1 * 1.75mm	Reel	1000

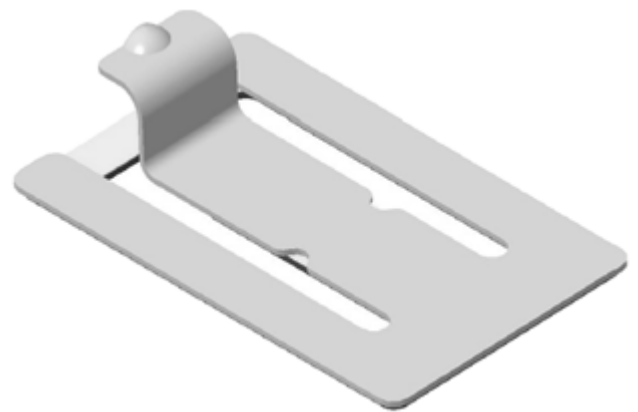
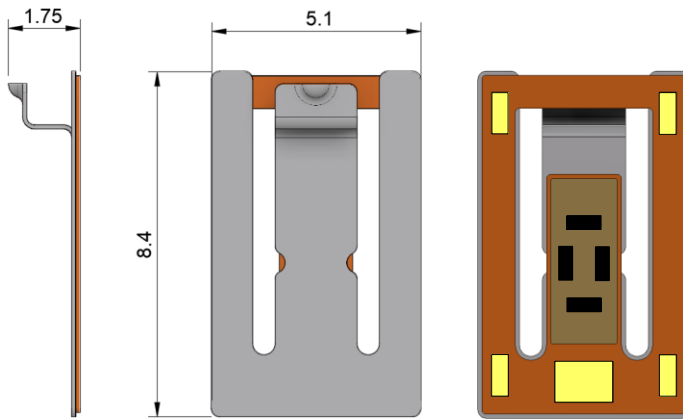

TABLE OF CONTENTS

	Page
TYPICAL APPLICATION	1
DESCRIPTION	1
ORDERING INFORMATION	1
PRODUCT DIMENSIONS & MATERIALS	2
PIN CONFIGURATION & FUNCTION	2
ABSOLUTE MAXIMUM RATINGS	2
ELECTRICAL CHARACTERISTICS	2
LAYOUT GUIDELINES & FOOTPRINT	3
SOLDERING PROFILE	3
PACKAGE INFORMATION	4
MOISTURE SENSITIVE LEVEL (MSL)	4
COMPLIANCE INFORMATION	4
REVISION HISTORY	4

PRODUCT DIMENSIONS & MATERIALS



Material:

- Stainless Steel for spring loaded cantilever
- Flexible Printed Circuits (FPC) as connector base

PIN CONFIGURATION & FUNCTION

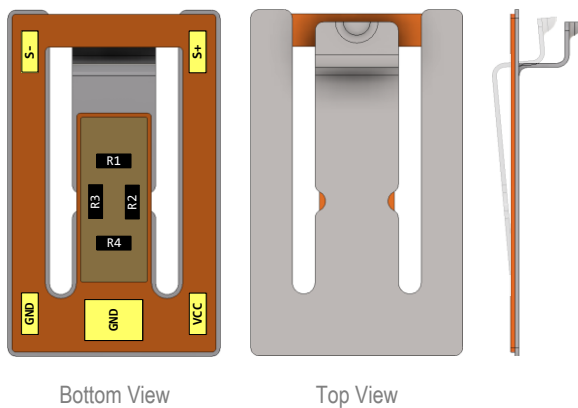

The movement of the cantilever causes R2 and R3 to bend. This changes the resistance value and results in an output signal. Recommended deflection is 0.5mm.

Pin name	Pin description
VCC	Sensor supply voltage
S+	Sensor positive output terminal
S-	Sensor negative output terminal
GND	Ground

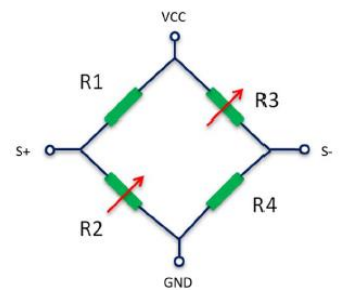

ABSOLUTE MAXIMUM RATINGS

Parameter	Unit	Min	Max
Supply voltage	V	0	10
Storage temperature	°C	-40	105
Operating temperature	°C	-40	105

ELECTRICAL CHARACTERISTICS

Parameter	Unit	Min	Typ	Max
Movement	mm	0	0	1.2
Output signal @ 3Vdc	uV/um		39	
Offset voltage @ 3Vdc	mV	-200	0	200
Linearity (R ²)			0.995	
Temp variation @ -20 to 50°C			30%	
Bridge resistance	kOhm	2	6	10

LAYOUT GUIDELINES & FOOTPRINT

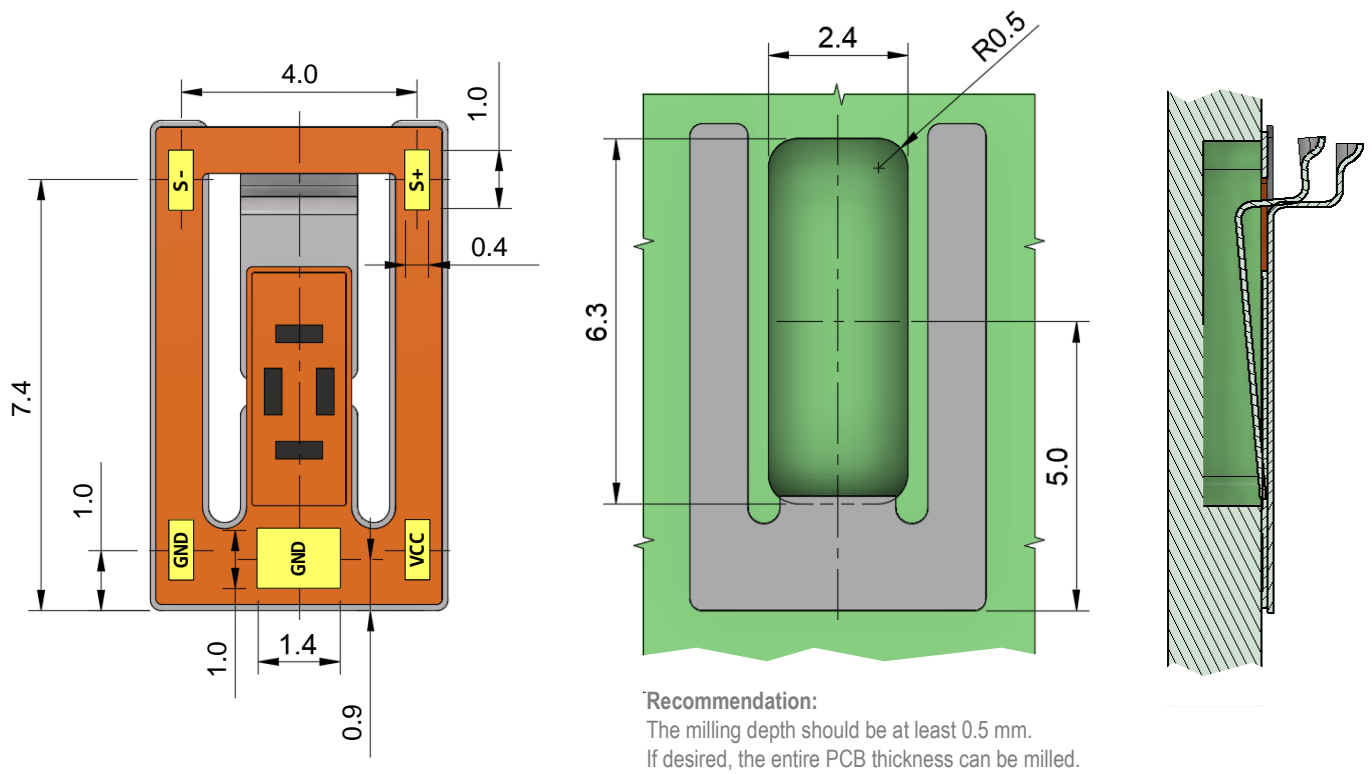

SOLDERING PROFILE

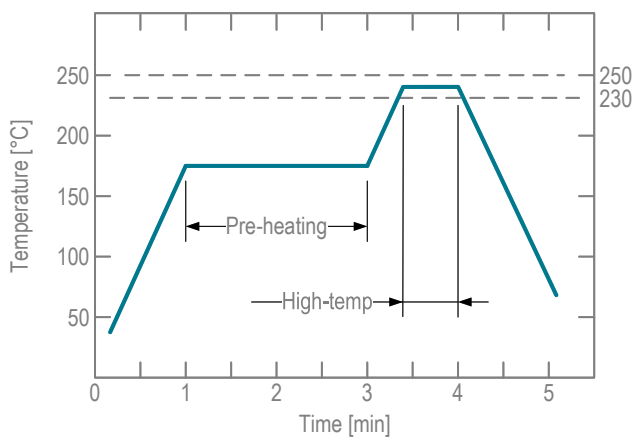

Pre-heating period	≥ 60s
Pre-heating temperature	<180°C
High-temperature period	30 to max 60s
Maximum soldering temperature	250°C

PACKAGE INFORMATION

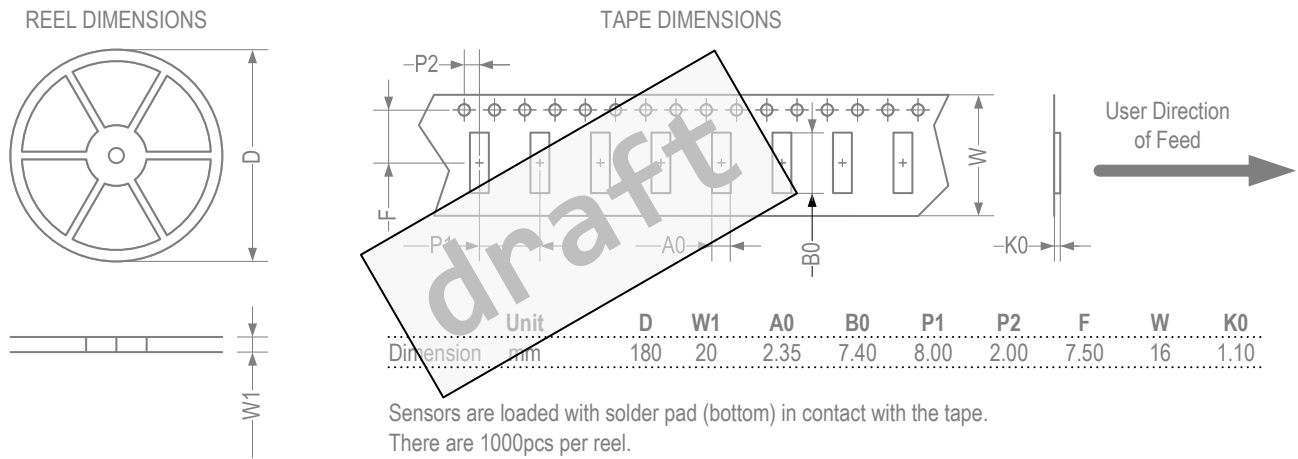

MOISTURE SENSITIVE LEVEL (MSL)

The Moisture Sensitivity Level rating according to the JEDEC industry standard classifications is Level-2.

COMPLIANCE INFORMATION

The PT215 sensor is in compliance with RoHS, REACH and CMRT. A written certification can be supplied upon request.

REVISION HISTORY

Version	Date	Description	Pages
V1.0	2024-01-18	Initial version	-